

PRODUCT FEATURES

CONSTRUCTION

- 12MM BIRCH VENEER PLYWOOD WITH HPL EXTERIOR FACE AND PVC INTERIOR FACE
- PENN ELCOM HARDWARE

FEATURES

- FRONT LID CAN BE SETUP ON THE RIGHT OR LEFT SIDE OF THE WORKSTATION
- SLAM LID LOCATED ON THE BACK
- DUAL POCKETS LOCATED ON THE LEFT SIDE WITH 100MM WIDTH
- PULL OUT KEYBOARD DRAWER
- GAS STRUTS SUPPORTED TOP LID
- FLIP OUT SECOND MONITOR

KEY MEASUREMENTS

- WORKBENCH HEIGHT AT 863MM
- FOLDABLE TABLE TOP HEIGHT 870MM

DESIGN SPECIFICATIONS

- EXTRA POCKETS TO STORE ACCESSORIES
- UNIT NEEDS TO HAVE REAR DOOR ACCESS
- GAS STRUTS TO BE USED INSTEAD OF RATCHET LID STAYS

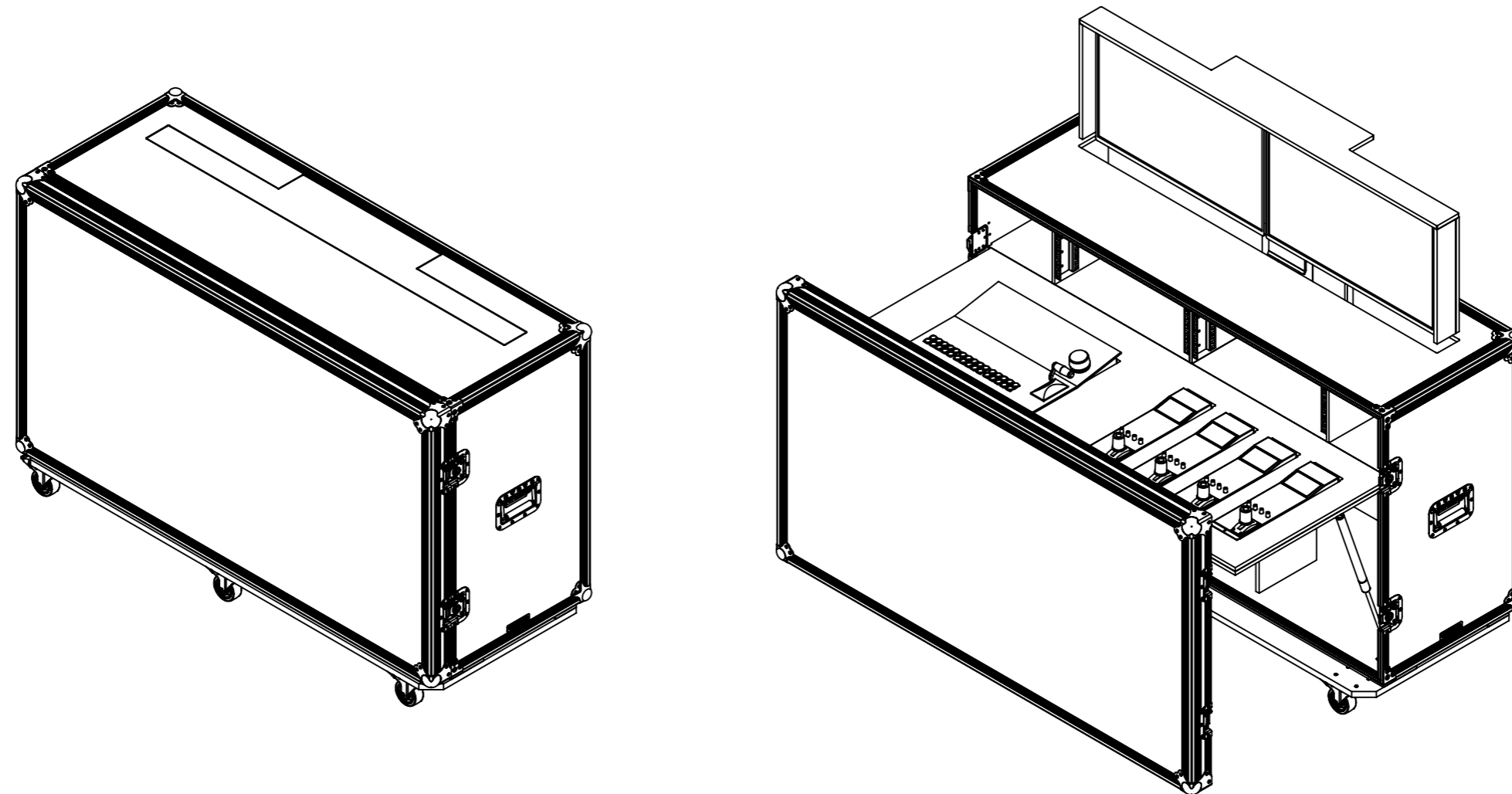
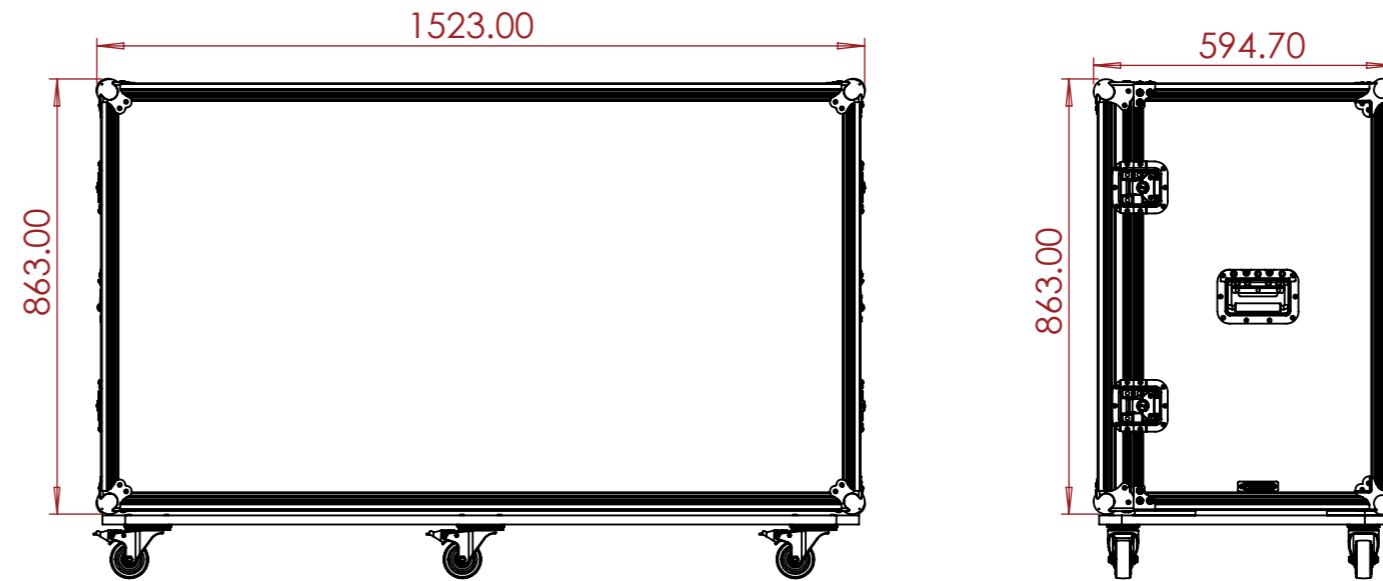

NOTES:

UNLESS SPECIFIED IN THE DRAWING, ALL PRODUCTS DISPLAYED IN THIS DRAWING OTHER THAN THE CASE ITSELF IS NOT PART OF OUR PRODUCT OFFERING.

ESTIMATED WEIGHT (CASE ONLY):

109.248 KG

ITEM CODE:

WS-SC Case

DRAWN BY:

CHECKED BY:

SCALE:

NTS



MAIL : sales@armorcases.com.au
WEB : www.armorcases.com.au