

PRODUCT FEATURES

- CONSTRUCTION:**
- 12MM HIGH QUALITY DOUBLE SIDED LAMINATED BIRCH PANEL
 - ARMOR HARDWARE

- INSTALLED EQUIPMENT(INCLUDED):**
- 17RU RACK STRIPS LOCATED AT FRONT AND BACK

- FEATURES:**
- FRONT LID CAN ACT AS TABLE FOR ADDITIONAL WORKSPACE
 - SLAM LID AND HATCH DOOR LOCATED AT THE BACK

- KEY MEASUREMENTS:**
- FOLDABLE TABLE TOP HEIGHT 850MM
 - FRONT AND REAR RACK STRIPS DISTANCE 568MM
 - REAR RACK STRIPS TO REAR PANEL 50MM

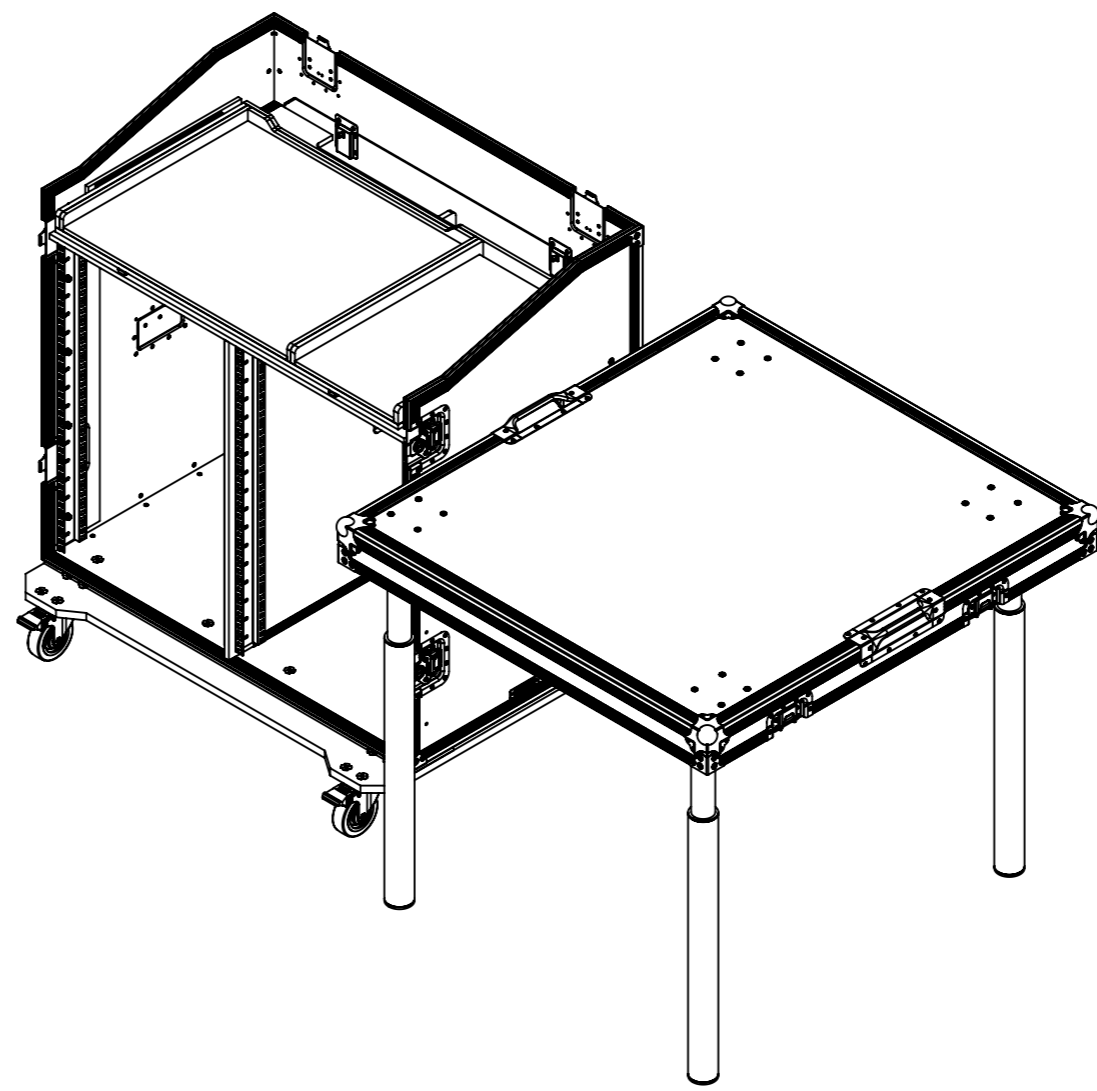
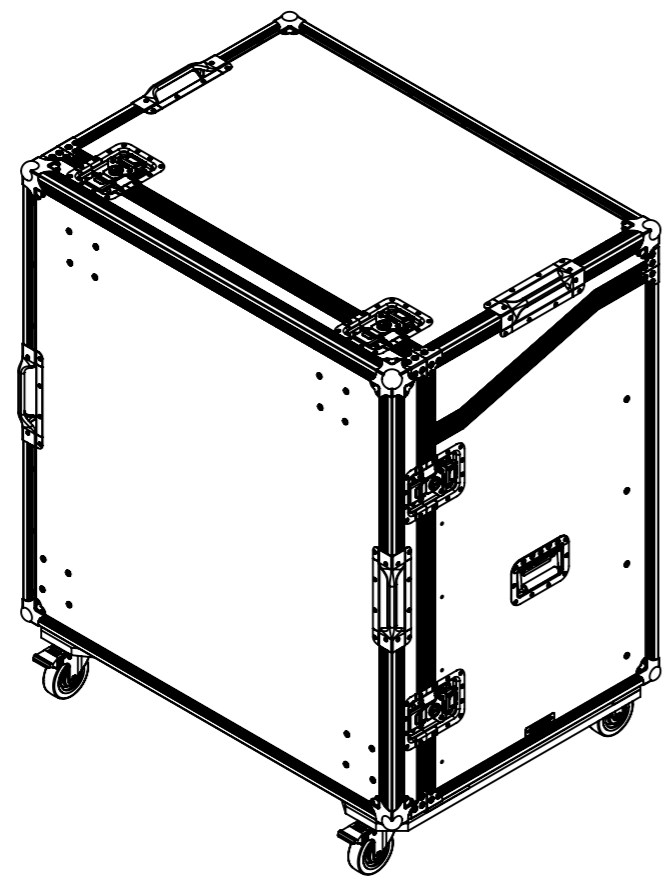
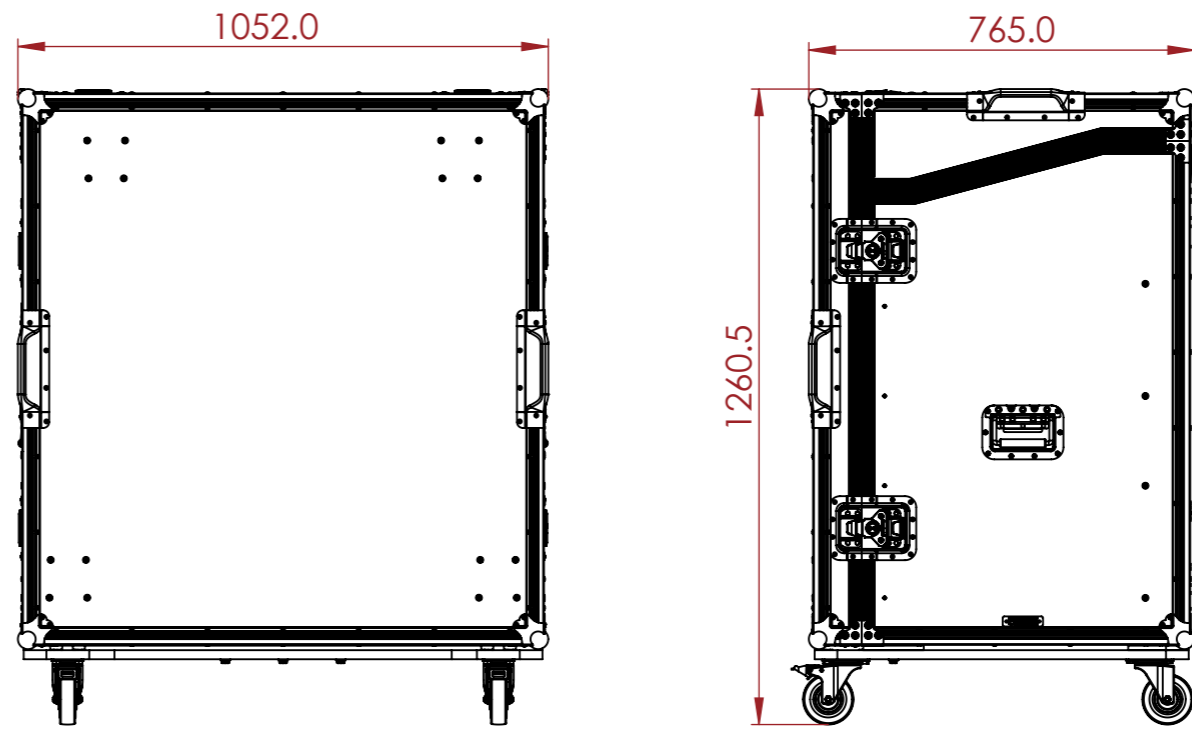

NOTES:
UNLESS SPECIFIED IN THE DRAWING,
ALL PRODUCTS DISPLAYED IN THIS
DRAWING OTHER THAN THE CASE
ITSELF IS NOT PART OF OUR PRODUCT
OFFERING.

ESTIMATED WEIGHT (CASE ONLY):
137.5 KG

ITEM CODE:
WS-AX

DRAWN BY: RP CHECKED BY: AS

SCALE:
NTS



MAIL : sales@armorcases.com.au
WEB : www.armorcases.com.au