

## PRODUCT FEATURES

### CONSTRUCTION

- 12MM BIRCH VENEER PLYWOOD WITH HPL EXTERIOR FACE AND PVC INTERIOR FACE
- PENN ELCOM HARDWARE

### INSTALLED EQUIPMENT (INCLUDED)

- 2X LARGE RECESSED HANDLES
- 4X LARGE LATCHES
- 4X 75mm CASTORS 2X BRAKED

### FEATURES

- LIFT OFF LID DESIGN
- GENERAL STORAGE FOR ACCESSORIES UNDER THE AMPLIFIER

### KEY MEASUREMENTS

- 65mm HEIGHT OF STORAGE UNDER THE AMPLIFIER

### DESIGN SPECIFICATIONS

- TRUCK FRIENDLY DIMENSIONS

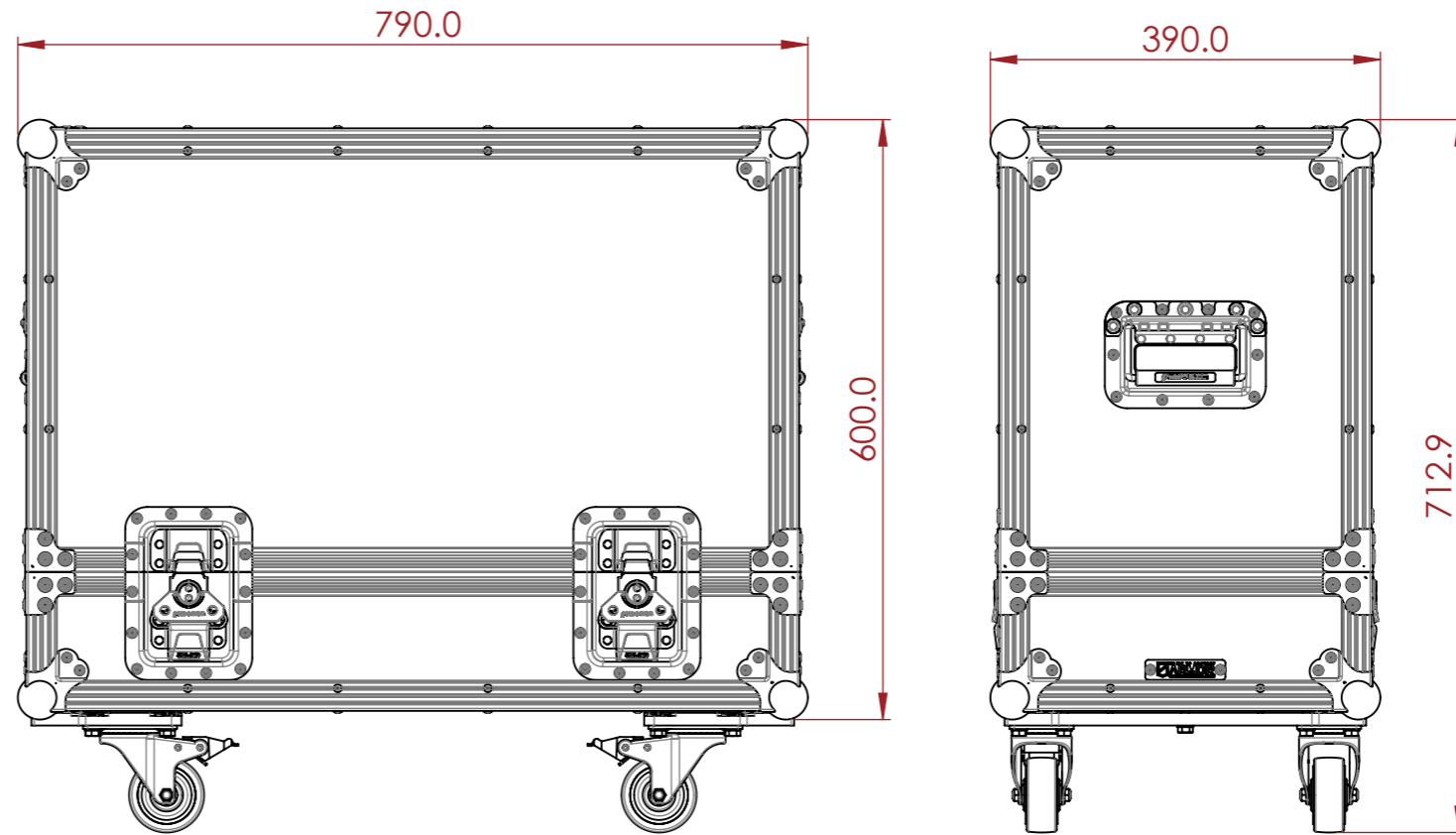

### NOTES:

UNLESS SPECIFIED IN THE DRAWING, ALL PRODUCTS DISPLAYED IN THIS DRAWING OTHER THAN THE CASE ITSELF IS NOT PART OF OUR PRODUCT OFFERING.

FENDER DELUXE REVERB 65 TX12in COMBO AMPLIFIER

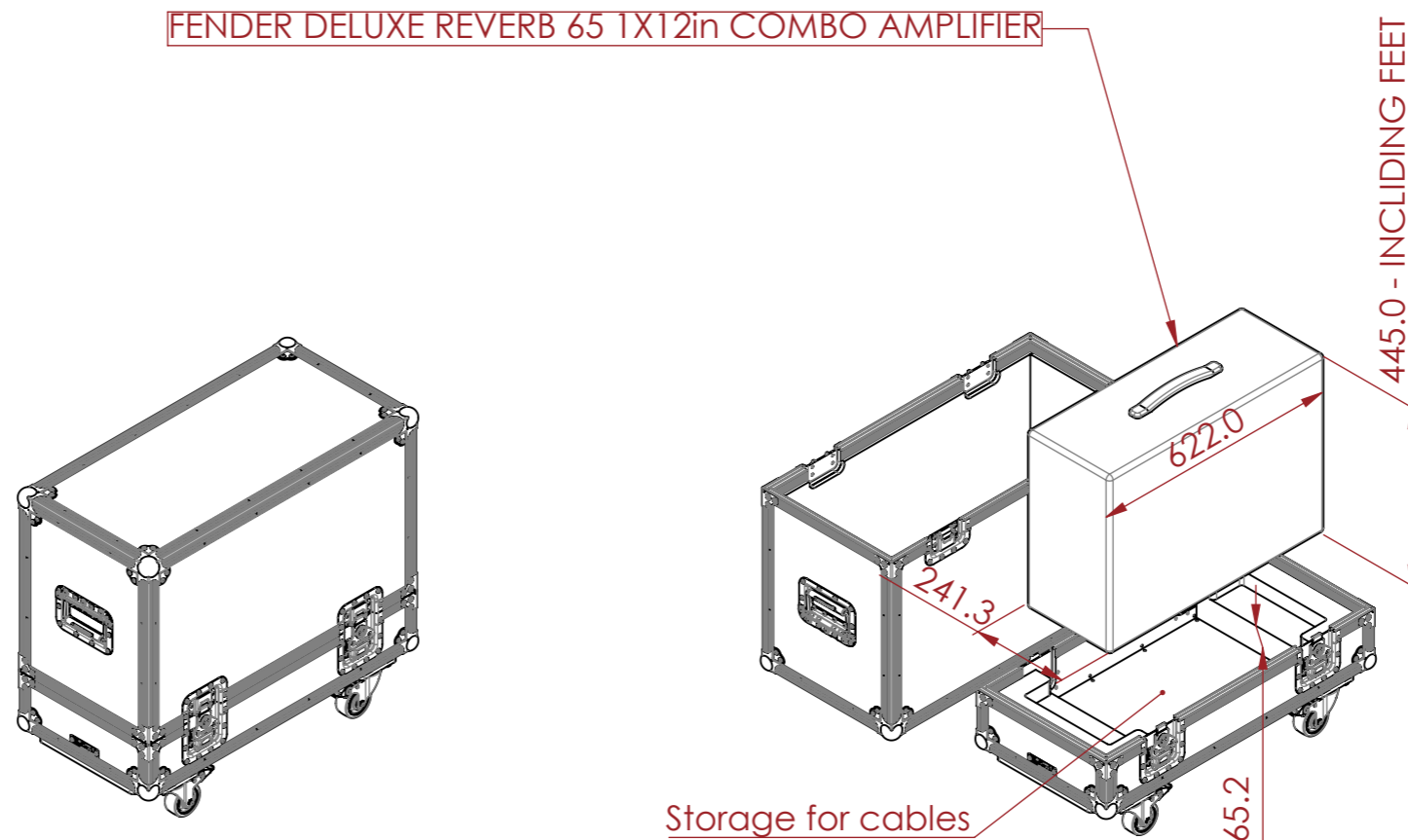

ESTIMATED WEIGHT (CASE ONLY):

27.3 KG

ITEM CODE:

AMP-FNDR-65DR-02

DRAWN BY:

HA

CHECKED BY:

AS

SCALE:

NTS



MAIL : [sales@armorcases.com.au](mailto:sales@armorcases.com.au)

WEB : [www.armorcases.com.au](http://www.armorcases.com.au)